

# MP3-CD Soundmachine

AZ3067

English

Meet Philips at the Internet  
<http://www.philips.com>

## User Manual

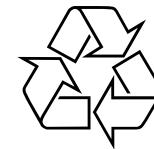

AZ 3067



Printed in China



**EXPANIUM**

**PHILIPS**

AL/JW-453-2

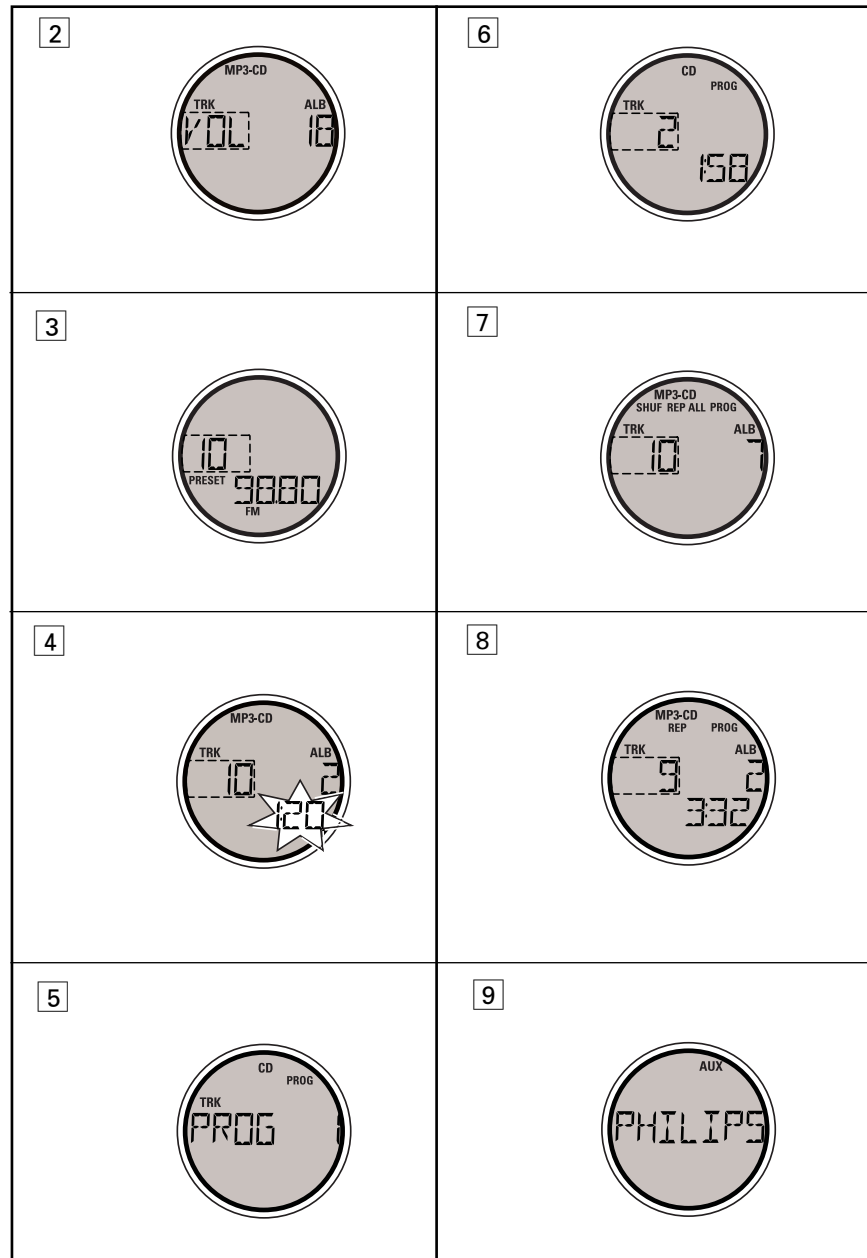
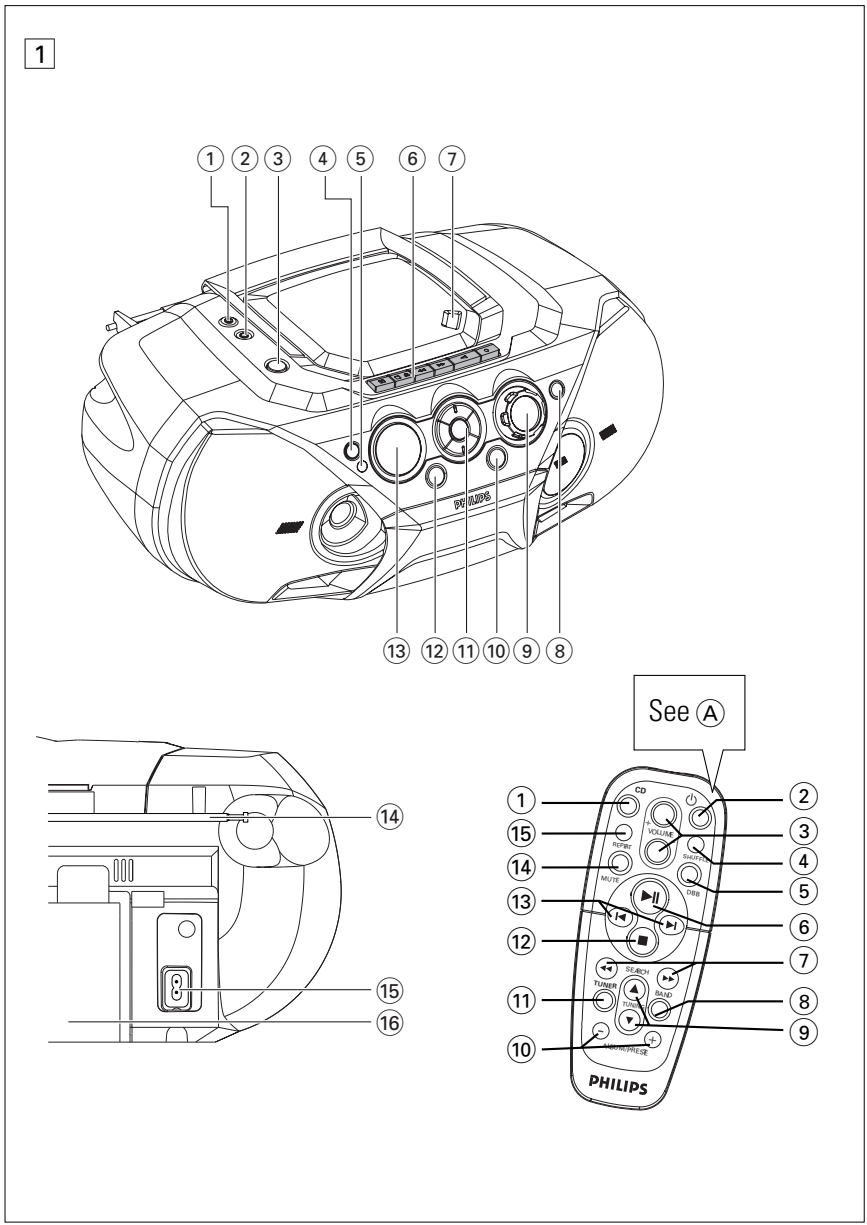

10

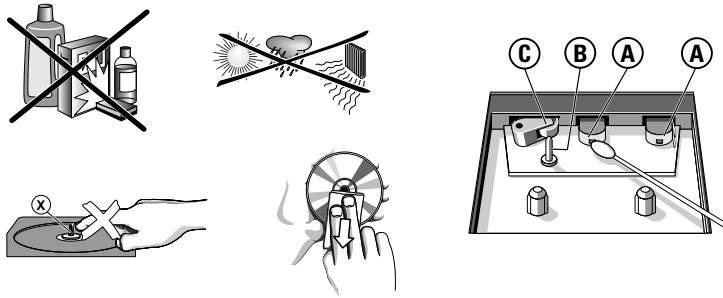

**IMPORTANT!**

*For users in the U.K.: please follow the instructions on the upper righthand-side.*

***This set complies with the radio interference requirements of the European Union.***

A

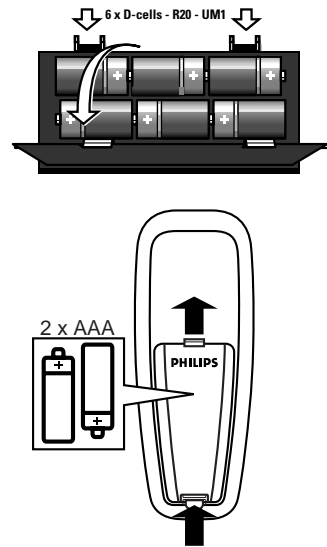

**Environmental information**

We have done our best to reduce the packaging and make it easy to separate into 3 materials: cardboard, expandable polystyrene, polyethylene.

Your set consists of materials which can be recycled if disassembled by a specialized company. Please observe the local regulations regarding the disposal of packaging, exhausted batteries and old equipment.

## English

### SUPPLIED ACCESSORIES

- AC mains lead
- Remote control

### TOP AND FRONT PANELS (See [1])

- ① – 3.5 mm stereo headphone socket  
**Helpful hints:** *The speakers will be muted when headphones are connected to the set.*
- ② **AUX** – 3.5 mm line-injack for external audio appliance
- ③ **STANDBY** – power on/ off switch
- ④ **Source selector** – selects CD(MP3-CD)/ TUNER/ AUX/ TAPE function
- ⑤ **IR Sensor** – infrared sensor for remote control
- ⑥ **Cassette recorder keys**  
**RECORD** – starts recording  
**PLAY** – starts playback  
**SEARCH** – fast winds/rewinds tape  
**STOP•OPEN** – opens the cassette compartment – stops the tape  
**PAUSE II** – pauses playback or recording
- ⑦ **OPEN•CLOSE** - press to open/close CD door
- ⑧ **DBB** – switches the bass enhancement on (DBB1 or DBB2) / off
- ⑨ **VOLUME** – adjusts volume level
- ⑩ **FM•MW**  
**TUNER:** selects wavebands  
**MP3:** display MP3-CD information
- ⑪ **Navigation controls**  
**PRESET (ALB/ PRE)** , – **MP3 only** : selects previous / next album.  
**TUNER** : selects a preset station.  
 – stops CD playback;  
– erases a CD programme  
**SEARCH** –  
**CD/MP3:** – searches backwards and forwards within a track;  
– skips to the beginning of a current/ previous/ later track  
**TUNER:** tunes to radio stations (*down, up*).  
**MODE** – selects different play modes: e.g. **REPEAT** or **SHUFFLE** (random order)  
**▶II** – starts or pauses disc playback

## CONTROL

- ⑫ **PROGRAM CD/MP3:** programs tracks and reviews the program;  
**Tuner:** programs preset radio stations
- ⑬ **Display** – shows the status of the set

### BACK PANEL

- ⑭ **Telescopic aerial** – improves FM reception
- ⑮ **AC MAINS** – inlet for mains lead
- ⑯ **Battery compartment** – for 6 batteries, type R-20, UM1 or D-cells

### REMOTE CONTROL (See [1])

- ① **CD** – switches the set on and selects CD/MP3 sound source
- ② – switches the set to standby / on if AC powered power. (Switches set off if battery powered)
- ③ **VOLUME +, -** (*up, down*) – adjusts volume level
- ④ **SHUFFLE** – selects shuffle modes
- ⑤ **DBB** – switches the bass enhancement on (DBB1 or DBB2)/ off
- ⑥ **▶II** – starts/ pauses disc playback
- ⑦ **SEARCH** , – searches backwards/ forwards within a disc track
- ⑧ **BAND** – selects wavebands
- ⑨ **PRESET (ALB/ PRE)** , – **MP3 only** : select next/ previous album.  
**TUNER** : select a preset station.
- ⑩ **TUNING - , +** – tunes to tuner stations
- ⑪ **TUNER** – switches the set on and selects tuner source
- ⑫ – stops disc playback;  
– erases a disc program
- ⑬ , – skips to the beginning of a current/ previous/ subsequent disc track
- ⑭ **MUTE** – interrupts/ resumes sound
- ⑮ **REPEAT** – select repeat modes

### CAUTION

**Use of controls or adjustments or performance of procedures other than herein may result in hazardous radiation exposure or other unsafe operation.**

## POWER SUPPLY

### MAINS SUPPLY

Whenever convenient, use the mains supply to conserve battery life. Make sure you remove the power plug from the set and wall socket before inserting batteries.

### Batteries (not included)

- Insert 6 batteries, type **R-20, UM-1** or **D-cells**, (preferably alkaline) with the correct polarity. (See [A])

### Remote control

- Insert 2 batteries, type **AAA, R03** or **UM4** (preferably alkaline). (See [A])

*Incorrect use of batteries can cause electrolyte leakage and will corrode the compartment or cause the batteries to burst.*

- Do not mix battery types: e.g. alkaline with carbon zinc. Only use batteries of the same type for the set.
- When inserting new batteries, do not try to mix old batteries with the new ones.
- **Batteries contain chemical substances, so they should be disposed of properly.**

### Using AC Mains

- 1 Check if the mains supply, as shown on the **type plate located on the bottom of the set**, corresponds to your local mains supply. If it does not, consult your dealer or service centre.
- 2 If your set is equipped with a voltage selector, adjust the selector so that it matches with the local mains.
- 3 Connect the mains lead to the wall socket.
- 4 To disconnect the mains supply, unplug the set from the wall socket.

### Auto-Standby mode

When a CD has reached the end of playback and remains in the stop position for more than 15 minutes, the set will switch off automatically to save mains.

**The type plate is located on the bottom of the set.**

## BASIC FUNCTIONS

### BASIC FUNCTIONS

#### Switching on and off and selecting function

- 1 Press **STANDBY** to switch on.
- 2 Press **Source selector** once or more to select: **CD (MP3-CD), TUNER, AUX** or **TAPE** function.
- 3 Press to switch off the set.

#### Helpful hints:

- To change from **TAPE** to **CD, TUNER** or **AUX** function, or when you are switching off the set: first, make sure you press the tape **STOP** key to end playback and all the cassette keys are released.
- The tone, sound settings, tuner presets and the volume level (up to a maximum volume level of 20) will be retained in the set's memory.

### ADJUSTING VOLUME AND SOUND

- Adjust the volume with the **VOLUME** control.  
→ Display shows the volume level and a number from 0-32. (See [2])

#### Bass adjustment

There are three **DBB** (Dynamic Bass Boost) options:

- **Off**: no bass enhancement
- **DBB1**: moderate bass enhancement
- **DBB2**: strong bass enhancement
- Press **DBB** once or more to select your option.  
→DBB1,2 appears if DBB is activated.

#### How to MUTE the sound

1. Press **MUTE** on the remote control to interrupt sound reproduction instantly.  
→ Playback continues without sound and in the display flashes **MUTE** .
2. To reactivate sound reproduction you can:
  - press **MUTE** again;
  - adjust the volume controls;
  - change to another source.

## DIGITAL TUNER

### DIGITAL TUNER

#### Tuning to radio stations

- 1 Press **⏻** to on, then press **Source selector** to select **TUNER** (or press **TUNER** on the remote control).
  - **TUNER** is displayed briefly and then the radio station frequency, waveband and, if programmed, a preset number are shown. (See [3])
- 2 Press **FM•MW** once or more to select your waveband. (or press **BAND** on the remote control)
- 3 Press and hold **SEARCH** **◀** or **▶** (or **TUNING -**, **+**) on the remote control until the frequency in the display starts running.
  - The radio automatically tunes to a station of sufficient reception. Display shows **SEARCH** during automatic tuning.
- 4 Repeat steps 2-3 if necessary until you find the desired station.
  - To tune to a weak station, press **◀** or **▶** briefly and repeatedly until you have found optimal reception.

#### To improve radio reception:

- For **FM**, extend, incline and turn the telescopic aerial. Reduce its length if the signal is too strong.
- For **MW**, the set uses a built-in aerial. Direct this aerial by turning the whole set.

#### Programming radio stations

You can store up to a total of 30 radio stations in the memory, manually or automatically (Autostore).

#### Manual programming

- 1 Tune to your desired station (see **Tuning to radio stations**).
- 2 Press **PROGRAM** to activate programming.
  - Display: **program** flashes.
- 3 Press **PRESET (ALB/ PRE) -**, **+** once or more to allocate a number from 1 to 30 for this station.
- 4 Press **PROGRAM** to confirm.
  - Display shows the preset number, waveband and the frequency of the preset station.
- 5 Repeat steps 1-4 to store other stations.

**Helpful hints:** You can erase a preset station by storing another frequency in its place.

## DIGITAL TUNER

### Autostore

Autostore automatically starts programming radio stations from preset 1. Any previous presets e.g. manually programmed will be erased.

- Press and hold **PROGRAM** until **AUTOSTORE** appears.
  - Available stations are programmed.
  - After all stations are stored, the first autostore preset station will then automatically play.

### To listen to a preset or autostore station

Press the **PRESET (ALB/ PRE) -**, **+** buttons once or more until the desired preset station is displayed.

## MP3-CD/CD PLAYER

### About MP3

The music compression technology MP3 (MPEG1 Audio Layer 3) significantly reduce the digital data of an audio CD while maintaining CD quality sound.

- **Getting MP3 files:** you can either download legal music files from the internet to your computer hard disc, or create such files by converting audio CD files in your computer through appropriate encoder software. (128kbps bit rate or higher is recommended for MP3 files.)
- **Creating a MP3 CD:** burn the music files from your computer hard disc on a CDR or CDRW using your CD burner.

#### Helpful Hints:

- Make sure that the file names of the MP3 files end with **.mp3**.
- Total number of music files and albums: around 350 (with a typical file name length of 20 characters).
- The length of file names affects the number of tracks for playback. With shorter file names, more files can be burned on a disc.

### Playing a disc

This player plays Audio Discs including CD-R/CD-RWs, and MP3 CDs.

- CD-I, CDV, VCD, DVD or computer CDs are not possible.
- 1. Press **STANDBY ON** **⏻** once or more to on, then select **CD** source (or press **CD** on the remote control).
- 2. Press **OPEN•CLOSE** to open the disc door.
  - Display show **CD** **OPEN** when the disc door is open.
- 3. Insert a disc with the printed side facing up and press down on **OPEN•CLOSE** to close the CD door.
  - **REFL** is displayed as the player scans the contents of a disc.
  - MP3-CDs may take more than 10 seconds to read.
  - Audio CD: the total number of tracks and the total playing time are displayed.
  - MP3-CD: the total numbers of tracks and albums are displayed respectively.
- 4. Press **▶II** to start playback.
  - **MP3-CD only:** the album/track information appears (if the ID3 tag information is available).

## MP3-CD/CD PLAYER

#### Helpful Hints:

– When playing a disc with CD Audio tracks and MP3 files, the CD Audio tracks will be played first..

– “0” is shown as your album number, if you have not organized your MP3 files into any albums on your disc.

5. To pause playback press **▶II**. Press **▶II** again to resume play.
  - Time digits flashes during pause. (See [4])

6. To stop playback, press **■**.

#### Helpful Hints:

MP3-CD / CD play will also stop when:

- the disc door is opened
- the disc has reached the end
- you select other sound sources.

### Display information (MP3-CD only)

The ID3 tag is part of an MP3 file and contains various track information such as the track's title or the artist's name.

- During playback, press **FM•MW** on the set repeatedly to view ID3 tag information or select your display function.
  - Display shows: **NO ID3 TAG** if ID3 tag information is not available.

#### Helpful Hints:

– Complete the ID3 tag information with your MP3 encoder software before burning the MP3-CD.

### Selecting a different track

- Press **SEARCH** **◀** or **▶** ( **◀** or **▶** on the remote control ) once or repeatedly until the desired track number appears in the display.
  - MP3-CD only:** First press **ALBUM/ PRESET -** or **+** once or more to find your album.
- In the pause/stop position, press **▶II** to start playback.

#### Helpful Hints:

– In shuffle modes, press **◀** to go to the beginning of the current track. .

## MP3-CD/CD PLAYER

### Finding a passage within a track

1. During playback, press and hold **SEARCH** ◀◀ or ▶▶ (◀◀ or ▶▶ on the remote control )
  - The disc is played at high speed and low volume.
  - No sound is heard during MP3-CD fast cue/review.
2. When you recognize the passage you want, release ◀◀ or ▶▶.
  - Normal playback continues.

### Programming track numbers

In the stop position, select and store your CD tracks in the desired sequence. Up to 20 tracks can be stored in the memory.

1. In the stop position, press ◀◀ or ▶▶ (on the remote control ◀◀ or ▶▶) once or repeatedly to select your desired track number.

#### MP3-CD only:

- First press **ALBUM/ PRESET** – or + once or more to find your album.
2. Press **PROGRAM**.
    - **PROG** and the number of tracks stored appear briefly. (See [5])
    - Display shows: **PROG** and the selected track number. (See [6])
  3. Repeat steps 1-2 to select and store all desired tracks.
  4. To start playback of your disc program, press ▶▶.

#### Helpful Hints:

- During normal playback, you can press **PROGRAM** to add a current track to your program list.
- **SELECT TRACK** appears if you press **PROGRAM** and there is no track selected.
- **FULL** appears if you try to store more than 20 tracks.

### Reviewing the program

- In the stop position, press and hold down **PROGRAM** for a while until the display shows all your stored track numbers in sequence.

## MP3-CD/CD PLAYER

#### Helpful Hints:

- Display shows : **NO PROG** if there is no track programmed.

### Clearing a program

You can erase the contents of the memory by:

- Press ■ :
    - Once, if in the stop position;
    - Twice, during playback.
  - Press **STANDBY ON** ⏻;
  - Select another sound source;
  - open the CD door
- **CLEAR** displayed briefly, and **program** disappears.

### Different play modes: SHUFFLE and REPEAT

(See [7] - [8])

You can select and change the various play modes before or during playback. The play modes can be combined with PROGRAM.

**shuffle** - tracks of the entire CD/ program are played in random order

**repeat all shuffle** - to repeat the entire CD/ program continuously in random order

**repeat all** - repeats the entire CD/ program

**repeat** - plays the current track continuously

1. To select play mode, press **MODE** once or more. (**SHUFFLE / REPEAT** on the remote control).

2. Press ▶▶ to start playback if in the stop position.
  - If you have selected **shuffle**, playback starts automatically.

3. To select normal playback, press **MODE** repeatedly until the various modes are no longer displayed.

- You can also press the ■ to cancel your play mode in playing.

## AUX / CASSETTE RECORDER

### AUX (audio cable not included) (See [9])

This 3.5mm socket allows you to connect other audio equipment to your system.

1. Press ⏻ to on, then the **source selector** to select **AUX**.
  - Display shows: **AUX** and **PHILIPS** scrolls
2. Use an audio cable to connect the AUX socket to the LINE OUT/headphone socket on your external equipment.
3. To avoid noise distortion, turn down the volume on your external equipment.
4. To adjust the sound and volume, use the sound controls on your external equipment and the AZ3067.

### Cassette recorder

#### Cassette playback

1. Press ⏻ to on, then the **source selector** to select **TAPE**.
  - Display shows **TAPE** throughout tape operation.
2. Insert a cassette and close the door.
3. Press **PLAY** ◀ to start playback.
4. To pause, press **PAUSE II**. Press **PAUSE II** again to resume.
5. Press **SEARCH** ◀◀/▶▶ to fast wind the tape.
6. To stop the tape, press **STOP•OPEN** ■▲.

#### Helpful Hints:

– During playback, the keys are automatically released at the end of a tape and the set is switched off (unless PAUSE mode II has been activated.)

– During fast forwarding/rewinding, the keys will not be released at the end of a tape. To switch off the set, make sure the cassette keys are also released. .

## CASSETTE RECORDER

### GENERAL INFORMATION ON RECORDING

- Recording is permissible insofar as copyright or other rights of third parties are not infringed.
- For recording, use only NORMAL type cassettes (IEC type I) on which the tabs have not yet been broken. This deck is not suited for recording on CHROME (IEC II) or METAL (IEC IV) type cassettes.
- The best recording level is set automatically. Altering the **VOLUME** or **BASS** controls will not affect the recording.
- To protect a tape from accidental erasure, break out the tabs. If you wish to record again, cover the tabs with a piece of adhesive tape.

### CD Synchro Start recording

- 1 Select CD function.
- 2 Insert a CD and if desired, programme track numbers.
- 3 Open the cassette door.
- 4 Insert a suitable tape into the cassette deck and close the door.
- 5 Press **RECORD** ● to start recording.
  - Playing of the CD/program starts automatically from the beginning. You don't need to start the CD player separately.
  - To select and record a particular passage within a CD track:
    - Press ◀◀ or ▶▶. Release the control when you recognize the passage you want.
    - To pause CD playback, press ▶▶.
    - Recording starts from this exact point in the track when you press **RECORD** ●.
- 6 To pause recording, press **PAUSE II**. Press **PAUSE II** again to resume recording.
- 7 To stop recording, press **STOP/OPEN** ■▲.

### Recording from the Radio

- 1 Tune to the desired radio station (see Tuning to radio stations).
- 2 Follow steps 3-7, under CD Synchro Start recording.



## MAINTENANCE & SAFETY

### MAINTENANCE & SAFETY (See 10)

#### CD player and disc handling

- If the CD player cannot read CDs correctly, use a cleaning CD to clean the lens before taking the set to repair.
- The lens of the CD player should never be touched!
- Sudden changes in the surrounding temperature can cause condensation on the lens of your CD player. Playing a CD is then not possible. Do not attempt to clean the lens but leave the set in a warm environment until the moisture evaporates.
- Always close the CD door to avoid dust on the lens.
- To clean the CD, wipe in a straight line from the centre towards the edge using a soft, lint-free cloth. Do not use cleaning agents as they may damage the disc.
- Never write on a CD or attach any stickers to it.

#### Tape deck maintenance

To ensure quality recording and playback of the tape deck, clean parts (A), (B) and (C) as shown, once a month. Use a cotton bud slightly moistened with alcohol or a special head cleaning fluid to clean the deck.

- 1 Open the cassette door.
- 2 Press **PLAY** ◀ and clean the roller (C).
- 3 Press **PAUSE** II and clean the heads (A), and the capstan (B).
- 4 After cleaning, press **STOP/OPEN** ■▲.

#### Safety Information

- Place the set on a hard, flat and stable surface so that the system does not tilt.
- Do not expose the set, batteries, CDs to humidity, rain, sand or excessive heat caused by heating equipment or direct sunlight.
- The apparatus shall not be exposed to dripping or splashing.
- Adequate ventilation with a minimum gap of 6 inches between the ventilation holes and surrounding surfaces is necessary to prevent heat build-up.
- The ventilation should not be impeded by covering the ventilation openings with items, such as newspapers, table-cloths, curtains, etc..
- No objects filled with liquids, such as vases, shall be placed on the apparatus.
- No naked flame sources, such as lighted candles, should be placed on the apparatus.
- The mechanical parts of the set contain self-lubricating bearings and must not be oiled or lubricated.
- To clean the set, use a dry cloth. Do not use any cleaning agents containing alcohol, ammonia, benzene or abrasives as these may harm the housing.

## TROUBLESHOOTING

If a fault occurs, first check the points listed below before taking the set for repair. If you are unable to remedy a problem by following these hints, consult your dealer or service centre.

**WARNING: Do not open the set as there is a risk of electric shock! Under no circumstances should you try to repair the set yourself, as this will invalidate the warranty.**

#### No sound /power

- Volume not adjusted
- Adjust the VOLUME
- Power Cord not securely connected
- Connect the AC power cord properly
- Batteries flat / incorrectly inserted
- Insert (fresh) batteries correctly
- Headphones connected to the set
- Disconnect headphones
- Electrostatic discharge/interference
- Unplug the set. If batteries inserted, remove batteries from the battery compartment. Press and hold **STANDBY ON** ⏻ for 10 seconds, then re-plug / replace battery supply, and try activating the set again.
- CD contains non-audio files
- Press **SEARCH** ◀◀ or ▶▶. once or more to skip to a CD audio track, instead of the data file

#### Severe radio hum or noise

- Electrical interference: set too close to TV, VCR or computer
- Move the set to increase the distance

#### Remote control does not function properly

- Batteries flat/ incorrectly inserted
- Insert (fresh) batteries correctly
- Distance/ angle between the set too large
- Reduce the distance/ angle

#### Poor radio reception

- Weak radio signal
- FM / MW: Adjust the FM / MW telescopic aerial

#### NF DISC indication

- CD-R(W) is blank/ not finalized
- Use a finalized CD-R(W)

#### INSERT DISC/CHECK DISC/DISC ERROR indication

- No CD inserted
- Inserted a suitable disc
- CD badly scratched or dirty
- Replace/ clean CD, see Maintenance
- Laser lens steamed up
- Wait until lens has cleared

#### The CD skips tracks

- CD damaged or dirty
- Replace or clean CD
- shuffle or program is active
- Switch off shuffle / program

#### Sound skips during MP3 playback

- MP3 file made at compression level exceeding 320kbps
- Use a lower compression level to record CD tracks into MP3 format
- Disc damaged or dirty
- Replace or clean disc

#### Poor cassette sound quality

- Dust and dirt on the heads, etc.
- Clean deck parts, see Maintenance
- Use of incompatible cassette types (METAL or CHROME)
- Only use NORMAL (IEC I) for recording

#### Recording does not work

- Cassette tab(s) may be broken
- Apply adhesive tape over the missing tab space